



KINEMATICA

Homogenizing perfected.

MEGATRON®



MEGATRON® MT 3100 S²
Instruction manual

**Garantie
Warranty
Upgrade**











Jetzt registrieren / Register now:
kinematica.ch/garantie-upgrade
kinematica.ch/warranty-upgrade

SAFETY INDICATIONS









Please pay attention to the meaning of the following warning signs:

	SAFETY INSTRUCTIONS MUST BE OBSERVED TO ENSURE SAFE OPERATION
	THIS SYMBOL INDICATES HIGH VOLTAGE, WITH RISK TO HEALTH AND ENVIRONMENT
	CAUTION! BEWARE OF HOT SURFACE
	CAUTION! BEWARE OF HAZARDOUS CHEMICALS OR MATERIALS THAT ENDANGER HEALTH
	CAUTION! BEWARE OF ROTATING MECHANICAL PARTS
	CAUTION! DEVICE NOT DESIGNED FOR USE IN EXPLOSION DANGER ENVIRONMENT





GENERAL SAFETY INSTRUCTIONS

	RESPECT THE INSTRUCTIONS GIVEN IN THIS DOCUMENT
	READ THESE OPERATING INSTRUCTIONS BEFORE SWITCHING ON OR OPERATING THE EQUIPMENT
	IF YOU HAVE ANY QUESTIONS OR DOUBTS REGARDING OPERATING THE UNIT, DO NOT START OR OPERATE THE UNIT AND CONTACT YOUR DEALER OR NEAREST KINEMATICA SERVICE CENTER
	IMPROPER USE OF THE MACHINE / UNIT DUE TO UNAUTHORIZED PERSONNEL CAN LEAD TO DAMAGE ON THE MACHINE / UNIT AND / OR ENDANGER LIFE, CAUSE PERSONAL INJURY AND HARM THE ENVIRONMENT
	ALL AUTHORIZED PERSONNEL INVOLVED IN THE OPERATION, THE SERVICE OR THE REPAIR OF THE MACHINE / UNIT HAVE TO READ AND TO UNDERSTAND THIS MANUAL
	ONLY AUTHORIZED PERSONNEL / INTENDED USERS ARE ALLOWED TO USE THE MACHINE
	THE INTENDED USER ASSURES THAT THE MACHINE / UNIT WILL BE INSTALLED CORRECTLY IN ORDER TO FULFILL THE INTENDED APPLICATION AND AUTHORIZES OTHER QUALIFIED USERS TO WORK WITH THE MACHINE / UNIT. HE IS ALSO RESPONSIBLE TO INSTRUCT THE USERS OF THE MACHINE / UNIT
	THE SERVICE ENGINEER IS EMPLOYED BY THE INTENDED USER AND MAINTAINS THE MACHINE / UNIT DURING OPERATION. HE IS A SKILLED CRAFTSMAN WITH MECHANICAL, ELECTRICAL AND ELECTRONIC EDUCATION. THE SERVICE ENGINEER IS RESPONSIBLE FOR THE INSTALLATION AND START-UP OF THE

System	MEGATRON®		
Type	MT 3100 S ²		
Issue	3.1 / 29.01.2019		
Page	4	of	39







	MACHINE / UNIT AS WELL AS FOR THE MAINTENANCE AND REPAIR OF THE MACHINE / UNIT. HE MUST BE TRAINED ACCORDINGLY TO CARRY OUT ALL NECESSARY MAINTENANCE WORK
	ENSURE THAT ALL LEGAL AND ENVIRONMENTAL REGULATIONS OF THE COUNTRY WHERE THE MACHINE / UNIT WILL BE INSTALLED ARE FOLLOWED
	DO NOT MODIFY THE MACHINE / UNIT WITHOUT A WRITTEN CONFIRMATION BY KINEMATICA
	IT IS STRICTLY FORBIDDEN TO RUN THE MACHINE / UNIT WITH DISASSEMBLED OR BRIDGED SAFEGUARDS, FOR EXAMPLE SAFETY LIMIT SWITCH, EMERGENCY SWITCH OR COVER
	FOR REPAIRS, ONLY ORIGINAL SPARE PARTS SHOULD BE USED
	BEFORE STARTING INSPECTION AND MAINTENANCE WORK ON THE MACHINE / UNIT (SERVICE, REPAIR ETC.), ALL POWER SUPPLIES MUST BE DISCONNECTED
	THE DRIVE UNIT MAY ONLY BE OPENED BY AUTHORIZED KINEMATICA SERVICE STATIONS
	SERVICE AND MAINTENANCE SHALL ONLY BE PERFORMED BY AUTHORIZED AND SKILLED SERVICE ENGINEERS
	AFTER EVERY INSPECTION AND MAINTENANCE WORK ON THE MACHINE / UNIT (SERVICE, REPAIR ETC.), THE SERVICE ENGINEER HAS TO DO A TEST-RUN

System	MEGATRON®		
Type	MT 3100 S ²		
Issue	3.1 / 29.01.2019		
Page	5	of	39







	EAR PROTECTION SHOULD ALWAYS BE USED WHEN WORKING IN THE ENVIRONMENT OF THE MACHINE
	KEEP THIS OPERATING MANUAL NEARBY THE EQUIPMENT FOR FUTURE REFERENCE
	THIS DOCUMENT IS PART OF THE MACHINE / UNIT AND SHOULD NOT BE REMOVED OR STORED ELSEWHERE EASY ACCESS TO THE OPERATING AND MAINTENANCE CREW MUST BE GRANTED AT ALL TIMES
	ALTHOUGH MEGATRON® UNITS ARE DESIGNED FOR EASY USE, THIS DOES NOT RELEASE YOU FROM THE OBLIGATION TO INSPECT YOUR EQUIPMENT CAREFULLY AND TO CLEAN IT THOROUGHLY

System	MEGATRON®		
Type	MT 3100 S ²		
Issue	3.1 / 29.01.2019		
Page	6	of	39









WARNINGS

	ALL WARNINGS AND RECOMMENDATIONS IN THE FOLLOWING CHAPTERS MUST BE RESPECTED
	THE EQUIPMENT MAY NOT BE OPERATED IN EXPLOSIVE AREAS IT IS NOT ALLOWED TO WORK WITH FLUIDS WHICH ARE HIGHLY INFLAMMABLE IT IS NOT ALLOWED TO MIX MATERIALS WHICH CAN CAUSE STRONG EXOTHERMAL REACTIONS
	THE ELECTRICAL INSTALLATION MUST BE DONE BY A QUALIFIED ELECTRICIAN !
	ENSURE THAT THE RATED VOLTAGE OF THE EQUIPMENT MATCHES THE SUPPLY IT IS IMPORTANT THAT THE MAINS SUPPLY WHERE THE DEVICE IS PLUGGED IN COMPLIES WITH THE INFORMATION ON THE TYPE LABEL AND THE INTERNATIONAL STANDARDS FOR POWER SUPPLIES. IF NOT, SUCCESSFUL OPERATION CANNOT BE GUARANTEED
	ENSURE THAT ENOUGH FREE SPACE IS AVAILABLE AT THE BACKSIDE OF DEVICE, SO THAT EFFECTIVE AIR FLOW AND COOLING IS ASSURED. INSUFFICIENT COOLING MAY LEAD TO A DECREASE OF POWER OUTPUT
	THE DEVICE HAS TO BE PLACED IN A MANNER THAT DIRT OR FLUIDS CANNOT PENETRATE THROUGH THE VENTILATION SLOTS AT BACK SIDE OF THE DRIVE







System	MEGATRON®		
Type	MT 3100 S ²		
Issue	3.1 / 29.01.2019		
Page	7	of	39

	<p>DIRECTION OF ROTATION IS COUNTER-CLOCKWISE SEEN FROM FRONT ONTO THE COUPLING!</p> 
	<p>DRY-RUN OF MECHANICAL SEALS AND/OR SLIDE BEARINGS MUST BE AVOIDED!</p>
	<p>THE MECHANICAL SEAL MUST BE OPERATED WITH A SUITABLE SEALANT LIQUID</p>
	<p>THE QUENCH SYSTEM FOR THE MECHANICAL SEAL MUST BE MONITORED BY THE INTENDED USER</p>
	<p>THE INTENDED USER MUST ENSURE FLOW OF PRODUCT THROUGH THE UNIT AT ALL TIMES</p>
	<p>MEGATRON® DISPERSION WORKING CHAMBERS MAY NOT BE OPERATED DRY - THE MECHANICAL SEAL IS COOLED AND LUBRICATED BY THE MEDIUM BEING PROCESSED AND THE QUENCH MEDIUM. RUNNING DRY WILL DESTROY THE MECHANICAL SEAL</p>









System	MEGATRON®		
Type	MT 3100 S ²		
Issue	3.1 / 29.01.2019		
Page	8	of	39

	THE MAX. OPERATIONAL SPEED IS INDICATED ON THE DATA PLATE
	THE INTENDED USER HAS TO ENSURE THAT NO FOREIGN PARTICLES WHICH MIGHT LEAD TO A DAMAGE CAN PASS THROUGH THE UNIT
	THE ASSEMBLY AND DISASSEMBLY PROCEDURES ARE DESCRIBED IN THIS MANUAL THE UNIT IS ONLY ALLOWED TO BE OPERATED WHEN ASSEMBLED COMPLETELY
	NEVER PULL THE COUPLING DURING OPERATION - THE WORKING CHAMBER COULD FALL OUT OF THE COUPLING
	THE WORKING CHAMBER SHOULD BE CLEANED AFTER EVERY OPERATION
	THE INTENDED USER HAS TO ENSURE THAT USED SOLVENTS AND CLEANING MATERIALS ARE COMPATIBLE WITH THE MATERIAL OF THE SEALS AND COMPONENTS OF THE UNIT
	THE RESPONSIBILITY OF KEEPING THE OPERATING PARAMETERS SUCH AS PRESSURE, TEMPERATURE AND PRODUCT FLOW WITHIN THE SPECIFIED LIMITS LIES WITH THE INTENDED USER
	SHAFT SEALS ARE NOT ALLOWED TO BE SUBJECT TO PRESSURE

System	MEGATRON®		
Type	MT 3100 S ²		
Issue	3.1 / 29.01.2019		
Page	9	of	39

	IN THE EVENT THAT HAZARDOUS CHEMICALS OR MATERIALS THAT ENDANGER HEALTH CAN INFLUENCE THE SURROUNDINGS OR USE OF THE EQUIPMENT, APPROPRIATE COUNTERMEASURES MUST BE TAKEN
	WHEN HANDLING DANGEROUS PRODUCTS, TAKE CARE THAT THE LOCAL SAFETY REGULATIONS ARE RESPECTED
	AT LONG TERM USE, THE WORKING CHAMBER AND THE BEARING HOUSING / COUPLING MAY GET HOT - DANGER OF SKIN BURN
	WHEN THE LINE CORD IS PLUGGED, NEVER TOUCH THE COUPLING IN THE DRIVE - DANGER OF INJURIES DUE TO ROTATING EDGES
	IF THE MACHINE / UNIT IS USED FOR ANY OTHER PURPOSE THAN THE INTENDED APPLICATION OR IF THE MACHINE / UNIT WILL BE OPERATED BEYOND THE TECHNICAL DATA RANGE WITHOUT THE WRITTEN APPROVAL BY KINEMATICA, IMPROPER USE IS DECLARED AND KINEMATICA WILL TAKE NO RESPONSIBILITY, NOR WILL GRANT ANY GUARANTEE IMPROPER USE OF THE MACHINE / UNIT CAN RESULT IN PERSONAL INJURY OR IN DAMAGE OF THE EQUIPMENT KINEMATICA WILL NOT BE LIABLE AND WILL TAKE NO RESPONSIBILITY IN SUCH AN EVENT
	IF THE PROCESSED MEDIA TENDS TO HARDEN OR STICK IN THE WORKING CHAMBER, THE PRODUCT HAS TO BE REMOVED COMPLETELY FROM THE WORKING CHAMBER
	PAY ATTENTION THAT THE TEMPERATURE DIFFERENCE BETWEEN ACTUAL TEMPERATURE OF THE WORKING CHAMBER AND CLEANING TEMPERATURE IS KEPT TO A MINIMUM

System	MEGATRON®		
Type	MT 3100 S ²		
Issue	3.1 / 29.01.2019		
Page	10	of	39

	A TEMPERATURE SHOCK CAN DAMAGE STRUCTURAL COMPONENTS
	THE CLEANING LIQUID SHOULD BE COMPATIBLE WITH THE PARTS WETTED BY THE PRODUCT
	BEFORE CLEANING WITH SOLVENTS, CHECK THE COMPATIBILITY BETWEEN THE SOLVENT AND THE MATERIAL OF THE O-RINGS
	ALL MAINTENANCE WORK HAS TO BE DONE BY SPECIALISTS OR ENGINEERS
	BEFORE STARTING THE DISASSEMBLY, ALL ELECTRICAL PARTS HAVE TO BE DISCONNECTED
	BE SURE THAT THE MOTOR CANNOT BE STARTED FROM ANOTHER PERSON, WHILE YOU ARE WORKING
	CRANES AND/OR LIFTING EQUIPMENT MUST BE USED TO MOVE AND TRANSPORT HEAVY MACHINERY
	ALL PARTS HAVE TO BE INSPECTED FOR SIGNS OF WEAR AND DAMAGE AND, IF NECESSARY, THEY HAVE TO BE REPLACED

INSTRUCTION MANUAL			
System	MEGATRON®		
Type	MT 3100 S ²		
Issue	3.1 / 29.01.2019		
Page	11	of	39

	<p>BEFORE REASSEMBLY, ALL SCREWS HAVE TO BE GREASED</p> <p>NEVER GREASE THE SEALING FACES OF THE MECHANICAL SEALS</p>
---	---

RESIDUAL DANGERS

When the system/equipment is used in accordance with rules and regulations, residual dangers are minimal.

Residual danger	Countermeasures
Tripping over feed or re- turn lines	These should be laid appropriately.
Breakage of glass contain- ers Splashing of the product	Wear protective clothing (goggles etc.)
Hearing loss due to loud noise	According to the application ear protection must be used
Tilting of the device	Use stable, non-slip base

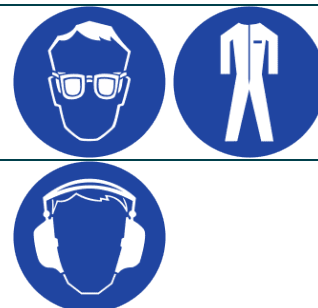

INSTRUCTION MANUAL			
System	MEGATRON®		
Type	MT 3100 S ²		
Issue	3.1 / 29.01.2019		
Page	12	of	39

1	INTRODUCTION	13
2	DESCRIPTION OF THE EQUIPMENT	14
2.1	DRIVE UNIT	15
2.2	WORKING CHAMBER	17
2.2.1	<i>DISPERSING GENERATORS.....</i>	<i>18</i>
2.2.2	<i>MECHANICAL SEAL</i>	<i>19</i>
2.2.3	<i>FITTINGS FOR PRODUCT INLET & OUTLET.....</i>	<i>20</i>
3	INSTALLATION AND START-UP	21
3.1	INSTALLATION	22
3.1.1	<i>MECHANICAL INSTALLATION.....</i>	<i>22</i>
3.1.2	<i>ELECTRICAL INSTALLATION.....</i>	<i>23</i>
3.2	START-UP	23
3.3	SHUT-DOWN	26
3.4	CLEANING.....	27
3.5	CHANGE LANGUAGE	27
4	MAINTENANCE WORK.....	28
4.1	MAINTENANCE AND INSPECTION PLAN.....	28
4.2	DISASSEMBLY AND ASSEMBLY OF STANDARD WORKING CHAMBER.....	29
4.2.1	<i>REPLACEMENT OF THE MECHANICAL SEAL</i>	<i>30</i>
4.2.2	<i>REPLACEMENT OF THE BALL BEARINGS</i>	<i>31</i>
4.2.3	<i>REPLACEMENT OF THE SHAFT SEALING RING.....</i>	<i>31</i>
4.2.4	<i>RESTART OF THE SYSTEM AFTER MAINTENANCE.....</i>	<i>31</i>
5	SPARE PARTS	32
5.1	ORDERING OF SPARE PARTS.....	32
5.2	RECOMMENDED SPARE PARTS.....	32
6	FAULTS AND REMEDIES	33
7	TECHNICAL DATA	34
7.1	DRIVE UNITS	34
7.2	WORKING CHAMBERS	36
7.3	DISPERSING GENERATORS	37
8	WARRANTY.....	38
9	DRAWINGS AND PARTS LIST.....	39

System	MEGATRON®		
Type	MT 3100 S ²		
Issue	3.1 / 29.01.2019		
Page	13	of	39

1 INTRODUCTION

KINEMATICA is a specialist for design and manufacturing of dispersing and mixing machines. The aim of this document is to instruct new users in the effective and safe utilization of our equipment.

The KINEMATICA Inline homogenizing system MEGATRON® MT 3100 S² has been designed and manufactured according the EC guidelines, the actual technical standards and applicable safety rules and is marked with the CE mark.

This document is valid for the KINEMATICA Inline homogenizing system MEGATRON® MT 3100 S².

The system is designed and manufactured for the intended application consisting of:

- In-Line processing of flowable and pumpable products under the considerations and limitations given in the "Technical Data".
- The processed media must be compatible with all constructional parts wetted by the product.
- If suitable precautions to personnel are taken to prevent any harm due to noise emission.
- The use of the system with no structural, mechanical or electrical changes different from the original scope of supply.

Typical applications:

- Preparing emulsions
- Pharmaceutical or cosmetics products
- Suspending solids in liquids (such as liquid polymers)
- Dispersing fine solids in liquids or molten phases
- Suspending additives and solid polymers in mineral oils
- Extracting enzymes from biomass
- Extracting active ingredients and substances from plants, for example (when used with REACTRON®)
- Grinding and shredding of solids and fibers in liquids or polymers

If the system is used for purposes different than or over and above the capabilities specified herein, KINEMATICA does not guarantee proper function and assumes no obligation or liability.

Should you have any questions which are not answered in this document, please contact KINEMATICA.

Check on www.kinematica.ch for your closest contact address.

System	MEGATRON®		
Type	MT 3100 S ²		
Issue	3.1 / 29.01.2019		
Page	14	of	39

2 DESCRIPTION OF THE EQUIPMENT

For a ready-to-use system you will need:

- Drive unit MEGATRON® MT 3100 S²
- A working chamber MTO/MTK 3100 Q
- A recirculation system (can also be supplied by the customer)



Example of a customized and extended

System	MEGATRON®		
Type	MT 3100 S ²		
Issue	3.1 / 29.01.2019		
Page	15	of	39

recirculation system

2.1 DRIVE UNIT

The drive unit contains the powerful three-phase high frequency motor (with quick coupling for the working chamber) controlled by the integrated VFD installed in a stainless-steel housing.



INSTRUCTION MANUAL			
System	MEGATRON®		
Type	MT 3100 S ²		
Issue	3.1 / 29.01.2019		
Page	16	of	39

System	MEGATRON®		
Type	MT 3100 S ²		
Issue	3.1 / 29.01.2019		
Page	17	of	39

2.2 WORKING CHAMBER

The working chamber is a flow through in line chamber.

The working chamber consists of the following general parts:

- Bearing
- Mechanical sealing
- Inner chamber with dispersing generator and product inlet/outlet connections
- Cooling/heating jacket (if applicable)

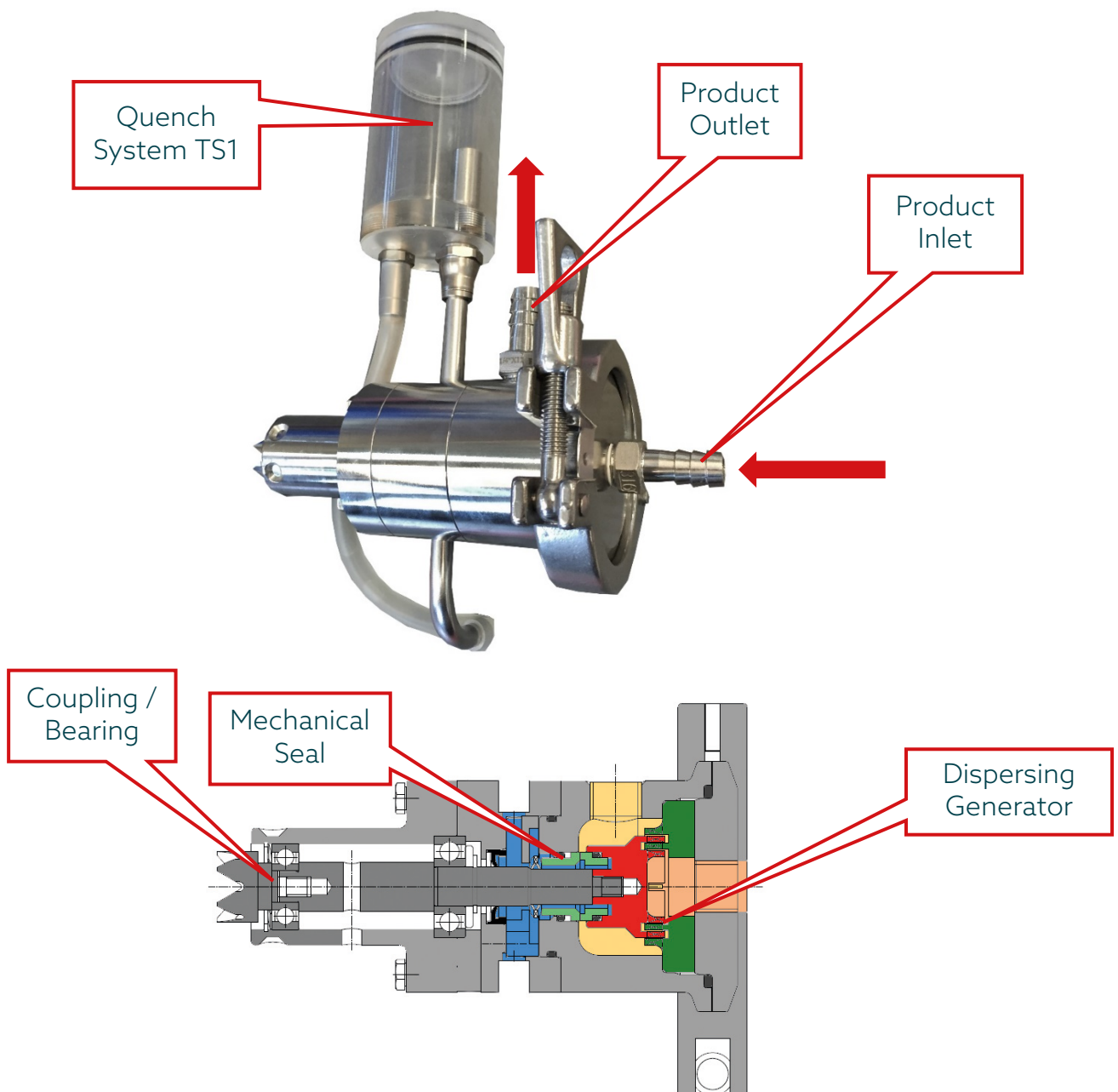

System	MEGATRON®		
Type	MT 3100 S ²		
Issue	3.1 / 29.01.2019		
Page	18	of	39

2.2.1 DISPERSING GENERATORS

A dispersing generator consists of a rotor and a stator. Rotor and stator consists of one or more teeth rows each for different levels of fineness.

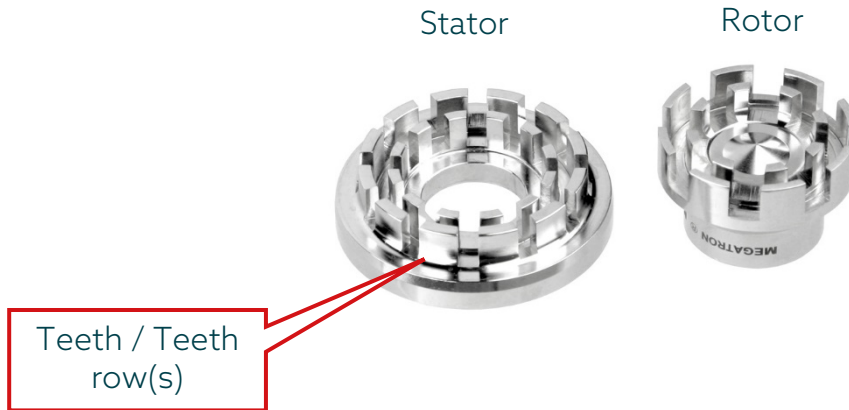

Turning with high speed, the rotor creates inside the stator high mechanical shear forces and shear stress resulting in size reduction and turbulent mixing of the processed media.

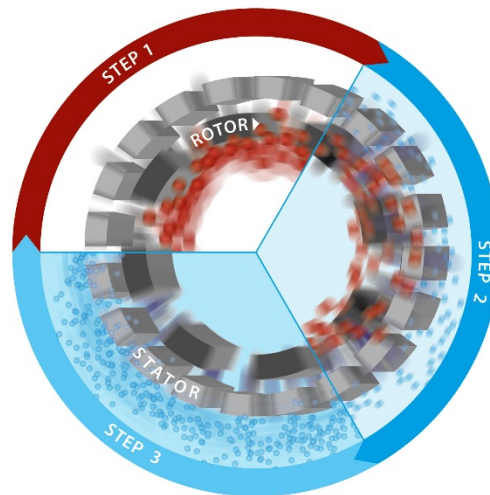

The generators are exchangeable with different types for different particle sizes.

Please bear in mind due to operation the dispersing generator(s) belong to the wear and tear parts.

System	MEGATRON®		
Type	MT 3100 S ²		
Issue	3.1 / 29.01.2019		
Page	19	of	39

2.2.2 MECHANICAL SEAL

The product side of the working chamber (inner chamber with dispersing generator) has to be separated from the non-product or atmospheric side of the working chamber. For that purpose, a single mechanical seal is installed inside the working chamber.

The type and material combination of the mechanical seal has been chosen for the application described in the contract and should therefore not be used for other purposes without the permission of the manufacturer.

A mechanical seal is not allowed to run dry. Moreover, it has always to be lubricated, flushed and cooled by a suitable sealing lubricant. The lubricant must also be compatible with the product and the materials of construction. The lubricant temperature has always to be 40°C below the boiling point to prevent any damages to the sealing system.

In the case of a single mechanical seal, a pressureless quench liquid system (flow through or pressureless tank) is used.

The standard working chambers for the MEGATRON® MT 3100 S² are equipped with a KINEMATICA quench system TS1 (also available with vessel made of PTFE)

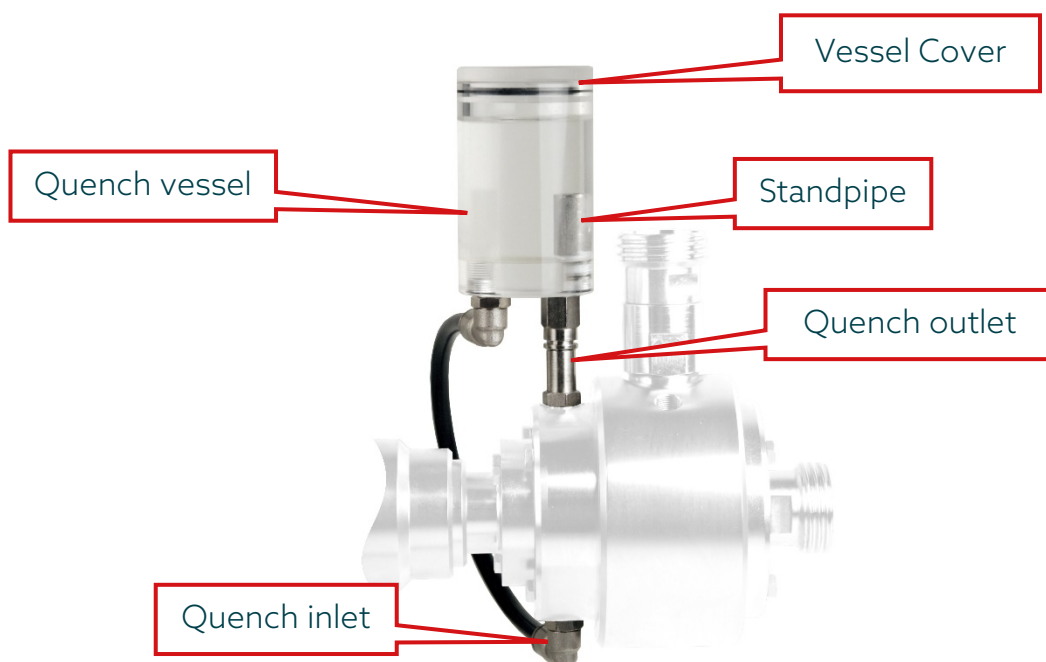

System	MEGATRON®		
Type	MT 3100 S ²		
Issue	3.1 / 29.01.2019		
Page	20	of	39



IF YOU DO NOT USE A QUENCH SYSTEM TS1, YOU HAVE TO CONNECT A FLOW-THROUGH, UNPRESSURIZED COOLING LIQUID PIPING (E.G. TAP WATER) AND A FLOW RATE \leq 1 L/MIN

2.2.3 FITTINGS FOR PRODUCT INLET & OUTLET

The standard inlet and outlet connections at the working chamber are inside thread G1/4".

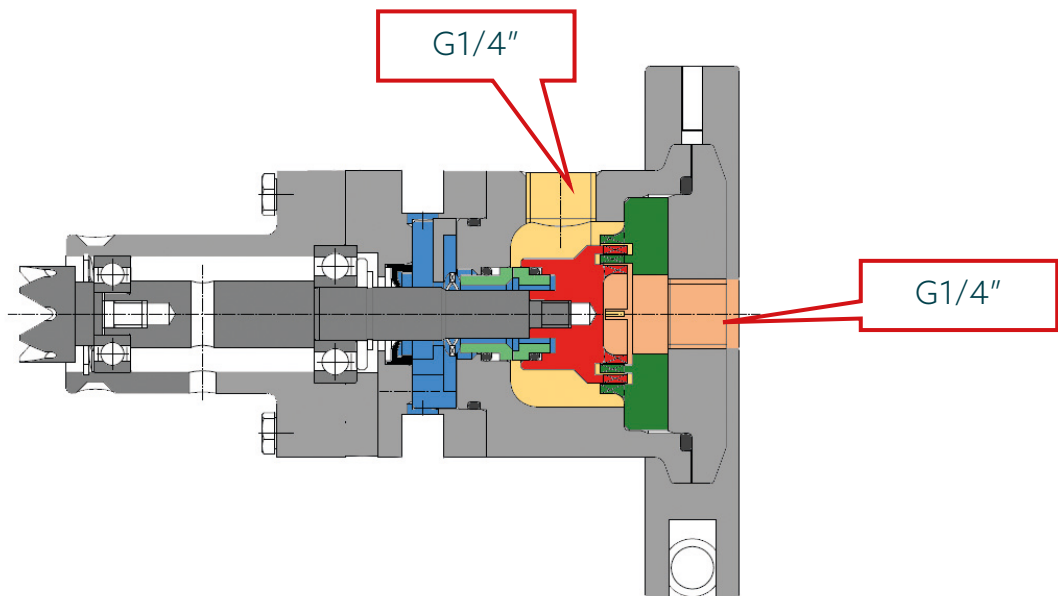

The MT 3100 S² working chamber is equipped with tube olive fittings \varnothing 12/8 as standard. Other fittings available on request.



INSTRUCTION MANUAL			
System	MEGATRON®		
Type	MT 3100 S ²		
Issue	3.1 / 29.01.2019		
Page	21	of	39

3 INSTALLATION AND START-UP

The drive unit MEGATRON® MT 3100 S² will be delivered completely assembled and the package will include:

- Drive unit
- Mains cable
- Manual

The working chamber will be delivered completely assembled and the package will include:

- Working Chamber (as ordered, optional)
- Dispersing Generator (as ordered, optional)
- Quench System (as ordered, optional)
- Product inlet & outlet fittings (as ordered, optional)
- Cooling/heating jacket (as ordered, optional)

Other accessories or equipment will be packed separately and delivered as ordered.

Always check the delivery note and check immediately when unpacking the unit. Always report immediately any irregularities.

System	MEGATRON®		
Type	MT 3100 S ²		
Issue	3.1 / 29.01.2019		
Page	22	of	39

3.1 INSTALLATION

3.1.1 MECHANICAL INSTALLATION

- The MEGATRON® has to be positioned on an even surface or foundation. Ensure that no vibrations can be transmitted onto the MEGATRON®. Please check if there is a sufficient air circulation.
- The working chamber has to be connected to the drive unit by using the quick coupling. Simply push back the slide ring of the quick coupling, fit the working chamber into the coupling and release the slide ring again.



System	MEGATRON®		
Type	MT 3100 S ²		
Issue	3.1 / 29.01.2019		
Page	23	of	39

- Check that the quick coupling has secured the working chamber against turning and/or removing.
- To remove the working chamber from the drive unit, simply push back the slide ring of the quick coupling and carefully remove the working chamber from the coupling.
- Connect product inlet and outlet lines and necessary supply lines (e.g. cooling water, sealing liquid...). A seal should always be used to avoid leakages. The piping should not generate any forces (stresses, vibrations) on the working chamber nozzles.

3.1.2 ELECTRICAL INSTALLATION

- Before connecting the electrical power supply using the mains cable, check the "Technical Data" as well as the data on the drive tag plate.

3.2 START-UP

- Check if all connections, piping and supply lines are tight and mounted correctly.
- Remove the cover of the quench vessel and fill up the quench system with the sealing liquid.
- The sealing liquid has to be compatible with the product, the seals and the mechanical seal. The sealing liquid is not within the scope of supply of KINEMATICA.
- Use enough sealing liquid so that the standpipe is always covered. Otherwise the mechanical seal will be damaged.
- Check that the filling level remains constant.



- Open the inlet and outlet product circuits.
- Check all connections, piping and supply lines for signs of leakage.

System	MEGATRON®		
Type	MT 3100 S ²		
Issue	3.1 / 29.01.2019		
Page	24	of	39

- The piping containing the product to be processed must be free of air pockets and air enclosures.
- For starting the MEGATRON®, push the On/Off button.



- In ON position, the main switch will light up and the speed display will show "Stop". The system is ready to start.



- Then push the green RUN "I" button in order to start the unit. The unit will increase the speed to the last set speed.



Speed indication

System	MEGATRON®		
Type	MT 3100 S ²		
Issue	3.1 / 29.01.2019		
Page	25	of	39

- Use the Up/Down buttons to increase or decrease the speed.



- The unit will increase/decrease the speed to the new set speed.

INFO: It is also possible to set first the desired speed level with the Up/Down buttons and then starting the unit with the green RUN "I" button. Before setting the speed, press the red Stop button twice until the speed indication blinks.

NOTE: The motor speed (rpm), motor current (A) and Output frequency (Hz) can be displayed by pushing the standard display functions' button.

Motor speed (RPM)

Output frequency (Hz), Motor current (A)



Motor current (A)

Power (kW), Motor speed (RPM)



Output frequency (Hz)

Motor current (A), Power (kW)



Standard display functions

System	MEGATRON®		
Type	MT 3100 S ²		
Issue	3.1 / 29.01.2019		
Page	26	of	39

3.3 SHUT-DOWN

- To shut down the unit, use the Down button and decrease the speed to "0" or "Standby".



- Afterwards push the red "Stop" button to stop the unit.



INFO: It is also possible to push the red STOP "O" button to stop the unit without decreasing the speed first. When pushing the green RUN "I" button again, the unit will increase again to the last set speed (Pause-Mode).

System	MEGATRON®		
Type	MT 3100 S ²		
Issue	3.1 / 29.01.2019		
Page	27	of	39

- Push the ON/OFF button. In OFF position, the light of the main switch and speed display will vanish and the system will shut down.



- Finally, close the inlet and outlet circuits (if applicable).

3.4 CLEANING

- If the processed media tends to harden or stick, the product has to be removed completely from the working chamber after every use.
- If the machine is not operated for a longer time or before any maintenance work is carried out, the working chamber has to be cleaned.
- There are different methods to clean the working chamber, depending on the customer's facilities:
 - The product can be pushed out under pressure. Do not use higher pressure than the normal working pressure to avoid damage to the mechanical seal and preventing the product from entering the bearing area
 - Or the working chamber can be disassembled.

3.5 CHANGE LANGUAGE

- Hold down the **Start**, **Navigate** and **Up** key for >1s.
- Use the **Up** and **Down** arrows to select a language.
- Press the **Navigate** button to select.

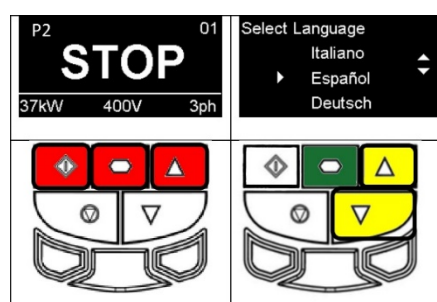

INSTRUCTION MANUAL			
System	MEGATRON®		
Type	MT 3100 S ²		
Issue	3.1 / 29.01.2019		
Page	28	of	39

4 MAINTENANCE WORK

- The MEGATRON® MT 3100 S² drive unit is designed to be almost maintenance-free. Nevertheless, the unit should always be used with care to guarantee a long lifetime.
- The attached working chamber contains several wear parts which have to be checked and/or exchanged regularly depending on the use of the unit, mainly:
 - Ball bearings
 - Mechanical Seal, Shaft Seal
 - O-Rings
 - Dispersing Generator
- Keeping these wear parts as spare parts on site is mandatory to avoid longer interruptions during maintenance and service – see also chapter “spare parts”.
- Before any maintenance work the working chamber of the MEGATRON® has to be rinsed out, emptied completely and cleaned.

4.1 MAINTENANCE AND INSPECTION PLAN

The MEGATRON® has to be inspected regularly in order to assure an optimum and safe operation.

DAILY INSPECTION WORK

If one of the following irregularities is found during inspection, the machine has to be stopped immediately and repaired:

- Leakage of the sealant fluid out of the opening in the mechanical seal housing
- Leakage of the whole piping system
- Overheated bearing housing
- Noise level too high or unusual noises
- Foreign body in the working chamber

YEARLY INSPECTION WORK OR EVERY 3000 RUNNING HOURS

- Signs of wear of the generator, deformation of the generator
- Phenomena of wear and damages on the mechanical seal
- Replacing the ball bearings

System	MEGATRON®		
Type	MT 3100 S ²		
Issue	3.1 / 29.01.2019		
Page	29	of	39

4.2 DISASSEMBLY AND ASSEMBLY OF STANDARD WORKING CHAMBER

This procedure is valid for the working chamber MTO 3100 Q (13032051).

Before demounting, please drain the working chamber completely and remove the quench connections.

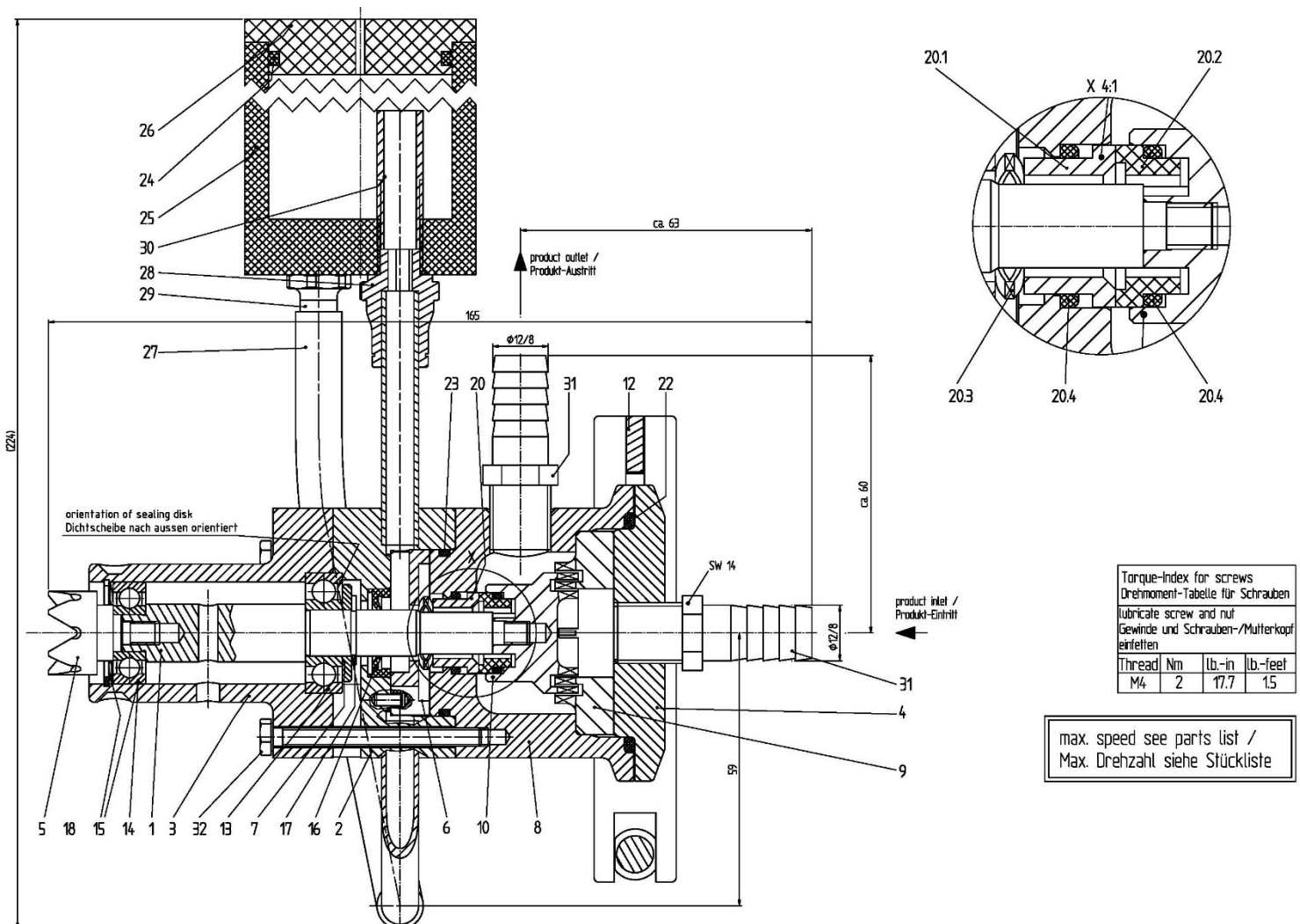

- Remove the inlet and outlet piping.
- Unfasten the clamp (12) and remove the inlet flange (4). Take care of O-ring (22).
- Remove the stator (9) carefully out of the working chamber.
- Fix the shaft (1) using a bolt (max. Ø 5 mm) and unfasten the rotor (10) using the disassembly tool. The rotating ring of the mechanical seal (20.2) will come off with the rotor.



- Unfasten the screws (32) and remove the chamber (8). The static ring of the mechanical seal (20.1) will come off with the chamber. Take care of the spring (20.3).
- Remove the seal housing (2). Take care of the mechanical seal disc (6) and the shaft seal (16).
- Unfasten the crown coupling (5).
- Push the shaft (1) with ball bearings (Pos. 13, 14) out of the bearing housing (3) into direction of the generator.
- If necessary, remove the locking ring (18) and the compensation disc (15) from the bearing housing (1).
- Remove the locking ring (Pos. 17) and pull off the centrifugal disc (7) as well as the ball bearings (13,14) from the shaft.
- Mount the new ball bearings on the shaft and dispose the used ones (do not re-install pulled off ball bearings).

4.2.1 REPLACEMENT OF THE MECHANICAL SEAL

When mounting the mechanical seal (20), assure that the spring is in the correct position. Assure that the slide areas of the mechanical seal are clean and do not contain any hard solid particles – solid particles in the slide areas may cause break down of the mechanical seal.

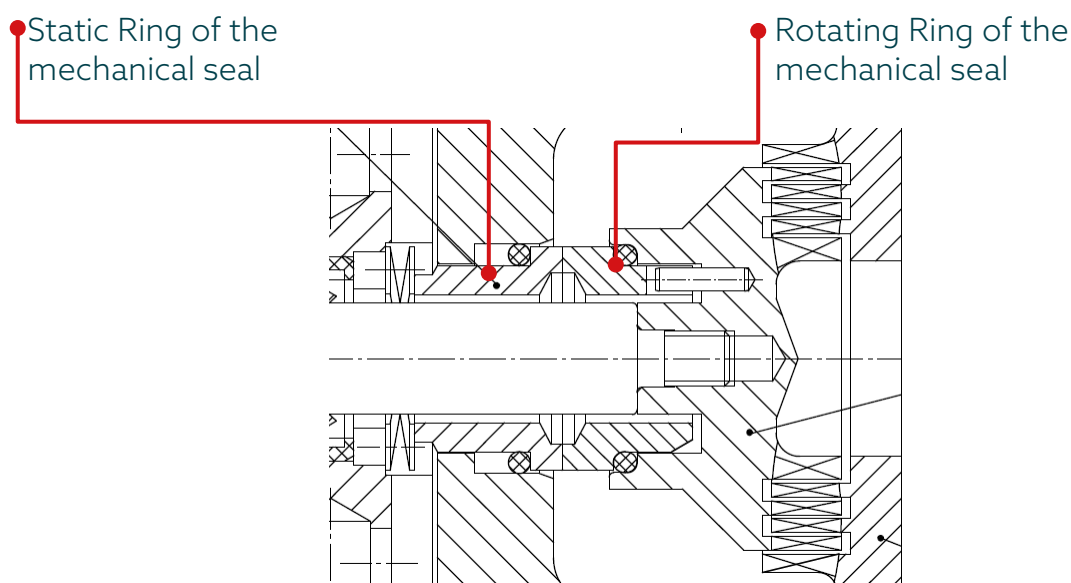
Mechanical seals have to be replaced as a complete set. Replacing just the static or the rotating face of the mechanical seal leads to strong and fast wear of the sliding faces.



	<p>PROTECT THE MECHANICAL SEAL AGAINST STROKES AND POKES, IT CAN BE DAMAGED EASILY</p> <p>NEVER GREASE THE SLIDE SURFACES AND ROTATING RINGS</p>
	<p>WHEN REPLACING THE MECHANICAL SEAL, DO NOT REPLACE SINGLE PARTS. WE RECOMMEND TAKING A WHOLE NEW SPARE MECHANICAL SEAL AND SEND THE DAMAGED ONE BACK TO THE NEAREST KINEMATICA REPRESENTATIVE</p>

4.2.2 REPLACEMENT OF THE BALL BEARINGS

To put on new ball bearings (13,14) on the shaft, they must be heat up to 120 °C (not more than 130°C). Heated ball bearings can then be mounted on the shaft without strong effort.

4.2.3 REPLACEMENT OF THE SHAFT SEALING RING

Grease the shaft sealing ring (16) before mounting it. Assure that the grease is in compliance with your application and product. When using EPDM sealings, never use grease based on mineral oil.

4.2.4 RESTART OF THE SYSTEM AFTER MAINTENANCE

The assembly of the working chamber has to be done in reverse order. Before starting up with real product, please assure the correct function of the system using water.

INSTRUCTION MANUAL			
System	MEGATRON®		
Type	MT 3100 S ²		
Issue	3.1 / 29.01.2019		
Page	32	of	39

5 SPARE PARTS

Only original KINEMATICA spare parts will guarantee a trouble-free operation of the machine.

See also "Technical Data" and the referenced documentation, drawings and parts lists.

5.1 ORDERING OF SPARE PARTS

When ordering spare parts, please indicate:

1. Type of machine (e.g. MEGATRON® MT 3100 S²)
3. Serial-No. indicated on the machine data plate (e.g. 823-0017-01-02)
3. Position, description and ident number according to the Parts List (e.g. Pos. 1, Shaft, 9750001)

5.2 RECOMMENDED SPARE PARTS

To avoid any inconvenience or time delays when handling service or repair cases, it is strongly recommended to hold on stock some main and/or critical components like:

- Mechanical seal
- Ball bearings
- O-Rings
- Shaft
- Dispersing Generator(s)

Please bear in mind that some components have lead times of several weeks.

Do not hesitate to contact KINEMATICA for a corresponding quotation or advice.

System	MEGATRON®		
Type	MT 3100 S ²		
Issue	3.1 / 29.01.2019		
Page	33	of	39

6 FAULTS AND REMEDIES

Fault	Possible causes	Remedy
Noise in the bearing housing	Dusty, dirty or damaged bearings	Replace the bearings
Rattle noise	Foreign body in working chamber	Remove foreign body
Vibrations	Twisted shaft	Replace the shaft
	Faulty bearings	Replace the bearings
	Foreign body in working chamber	Remove foreign body
	Rotational speed exceeded	Reduce the speed
Bearing housing hot	Faulty bearing housing	Replace bearing housing
	Damaged bearings	Replace bearings
	Wrong grease	Use specified grease
	Rotational speed exceeded	Reduce the speed
Leakage of sealing liquid	Mechanical seal damaged	Replace mechanical seal
No throughput of product	Air in working chamber	Remove air out of product line
	Viscosity of product too high	Install a feed pump in front of the MEGATRON®
Display shows "CL"	Current Limit reached, Motor overload	Verify drive/motor are proper size for application
Display shows "FCL"	Fast Current Limit, Overload	Verify drive/motor are proper size for application

System	MEGATRON®		
Type	MT 3100 S ²		
Issue	3.1 / 29.01.2019		
Page	34	of	39

7 TECHNICAL DATA

7.1 DRIVE UNITS

Description	Drive Unit MEGATRON® MT 3100 S ²			
Order Code	13010060	13010061	13010062	13010063
Plug type	CH	EU	UK	US
Motor type	AC motor 3-phase, gear-free direct drive			
Supply voltage	1-phase, 230 V ~			
Supply frequency	50-60 Hz			
Max. speed	30'000 rpm (+/- 2%)			
Input power	Max. 1'500 W			
Output power	Max. 1'200 W			
Soft-start	Yes			
Noise emission (drive only)	Lower than 62 dB(A)			
Direction of rotation	Counter clockwise, seen from front			
Ambient temperature	0 - 40°C			
Relative humidity	80% max. non-condensing			
Standards	Manufactured according to EN / IEC regulations for EMC & SAFETY			
Protection type	IP 20			
Max. period of continuous operation	100 %			
Coupling type	F			
Weight (drive only)	10.2 kg			

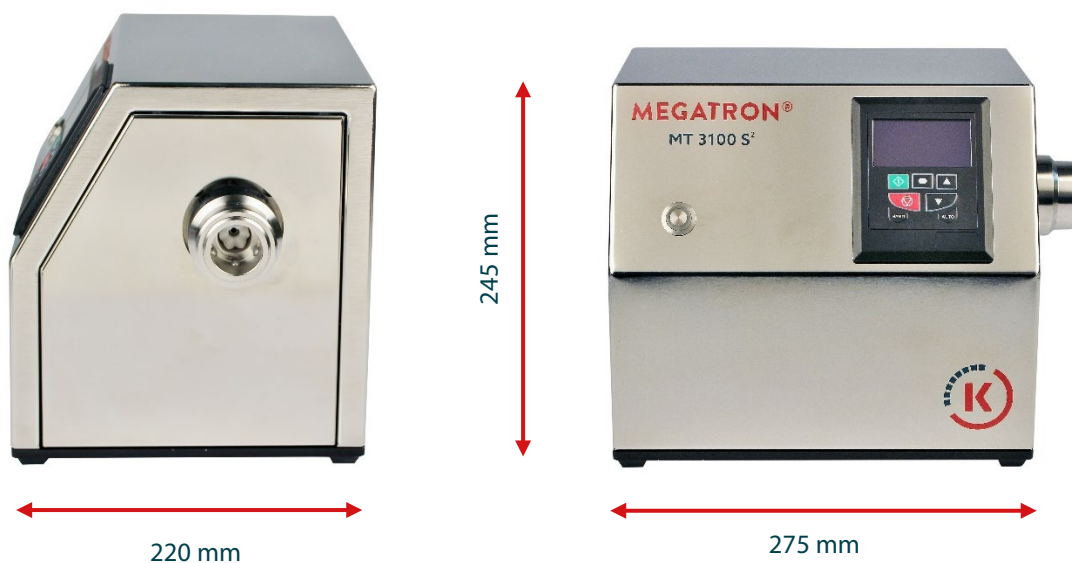

INSTRUCTION MANUAL			
System	MEGATRON®		
Type	MT 3100 S ²		
Issue	3.1 / 29.01.2019		
Page	35	of	39

System	MEGATRON®		
Type	MT 3100 S ²		
Issue	3.1 / 29.01.2019		
Page	36	of	39

7.2 WORKING CHAMBERS

Description	MTO 3100 Q	MTK 3100 Q
Order Code	13032051	13032053
Stages	1 (for one dispersing generator)	
Product connections	G1/4" / Tube olive fittings Ø12/8	
Cooling / Heating jacket	No	Yes, connections 2xG1/8"
Max. speed	30'000 rpm	
Working Temperature	max. 90°C	
Working pressure	max. 6 bar(g)	
Differential pressure	max. 2 bar(g) between product inlet-outlet	
Working pressure jacket	N/A	Max. 4 bar (g)
Mechanical Seal	Type 2031-010 QBV-G Q=Silicon-Carbide / B=Carbon / V=Viton / G=Stainless Steel	
Quench connections	Yes, tube Ø8x1 / G1/8"	
Quench vessel	Yes, Standard TS1, made from Plexiglas, incl. lid and seal	
Quench pressure	Pressureless (continuous or with quench vessel)	
Materials wetted by the product	Stainless steel 316 L O-Rings/Gaskets made of Viton	
Surface finish	Electropolished	
Surface roughness	Product wetted parts Ra ≤ 1.6 µm	
Product requirements	The product must be pumpable and must not contain solid particles that may destroy the mechanical seal	
Product Viscosity	Depending on the temperature, pressure and products properties, the dynamic viscosity should not exceed: Approx. 500 mPas	
CIP	No	
SIP	No	
Autoclavable	No	
Weight	Approx. 2.0 kg	Approx. 2.5 kg

Other versions incl. autoclavable design available on request.

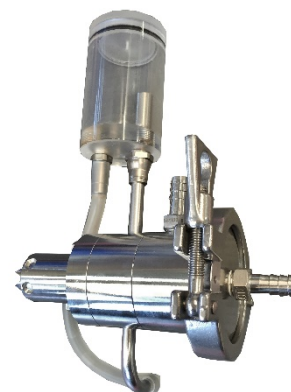

System	MEGATRON®		
Type	MT 3100 S ²		
Issue	3.1 / 29.01.2019		
Page	37	of	39

7.3 DISPERSING GENERATORS

Dispersing generators MTG ../. X

	13031520	13031530	13031531	13031532
Order code	13031520	13031530	13031531	13031532
Type	MTG 20/2 FFV	MTG 30/2 M	MTG 30/4 F	MTG 30/4 FFV
Rotor Ø	15.5 mm	24 mm	26 mm	26.5 mm
Stator Ø	20 mm	30 mm	30 mm	30 mm
Max. speed	30'000 rpm	30'000 rpm	30'000 rpm	30'000 rpm
Max. flow [l/min]	5	11	7	6
Materials	Stainless steel 316 L			
Surface finish	Electropolished			
Surface roughness	Ra 1.6 µm			
Cleaning	Sterilizable and autoclavable at all common methods			

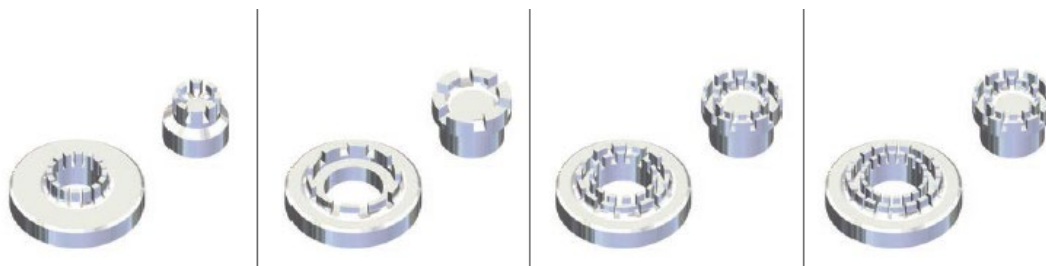

System	MEGATRON®		
Type	MT 3100 S ²		
Issue	3.1 / 29.01.2019		
Page	38	of	39

8 WARRANTY

KINEMATICA AG guarantees that the equipment that it produces will run free of any fault related to materials or manufacturing faults for **24 months**.

ADDITIONAL WARRANTY FOLLOWING REGISTRATION

Consumers who complete a warranty registration within 20 days of receiving their device will benefit from a free warranty extension of a further 12 months. This means that the total warranty period after registration is 36 months.

REGISTER NOW



kinematica.ch/warranty-upgrade

If thorough testing shows a fault to be due to either of the above causes, KINEMATICA AG guarantees that the equipment will be repaired or replaced free of charge. The guarantee does not cover parts that are subject to normal wear. It is void if any person other than an employee of KINEMATICA AG or their appointed representative has made modifications to the equipment or if the damage is due to failure to comply with the operating instructions, to carelessness, accident, incorrect use or incorrect supply voltage.

Please check our further warranty conditions and the correct procedure for a repair application on our website:

<http://www.kinematica.ch/en/contact-service/service-and-repair.html>

KINEMATICA AG reserves the right to make technical changes to the equipment without modifying equipment delivered earlier in the same way.

In the event of technical problems, for spare parts requirements or for advice, contact our regional appointed agent, your preferred dealer or us directly at:

KINEMATICA AG

Luzernerstr. 147a
CH-6014 Luzern
Switzerland

Tel. +41-41-259 65 65
Fax +41-41-259 65 75
Email service@kinematica.ch

INSTRUCTION MANUAL			
System	MEGATRON®		
Type	MT 3100 S ²		
Issue	3.1 / 29.01.2019		
Page	39	of	39

9 DRAWINGS AND PARTS LIST

The following drawings and parts list are suitable for the purchased MEGATRON® MT 3100 S².